

BILL OF MATERIALS

ITEM	DESCRIPTION
1	RHINO POST
2	W-BEAM GUARDRAIL
3	HANDRAIL EXTENSION PIECE
4	HANDRAIL 32NB
5	M16 x 50mm POST BOLT/NUT
6	M16 x 30mm HEX. BOLT/NUT
7	TEK SCREWS
8	M16 x 32mm SPLICE BOLT/NUT
9	M20 ANCHOR BOLT

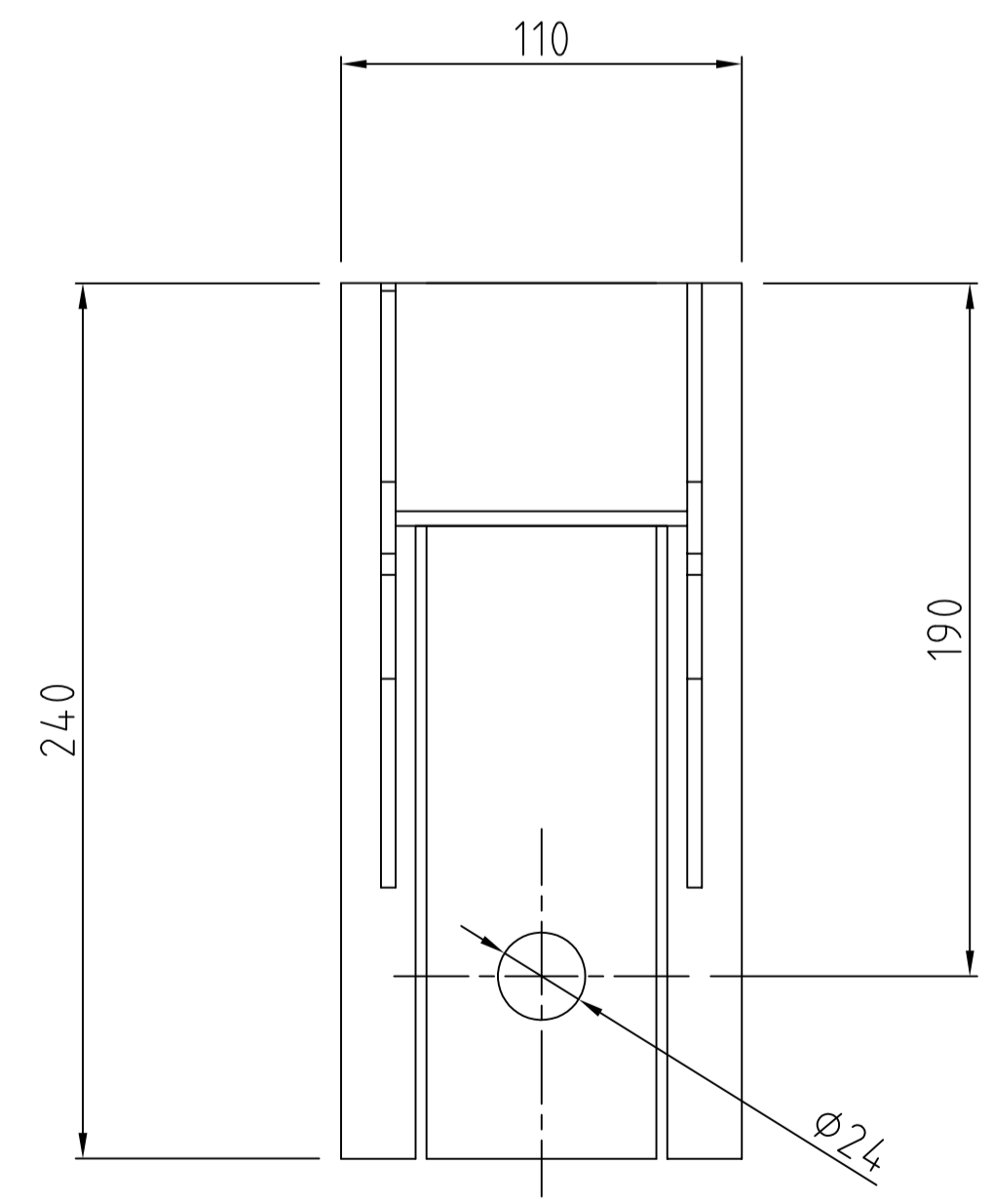

BASE PLATE DETAIL

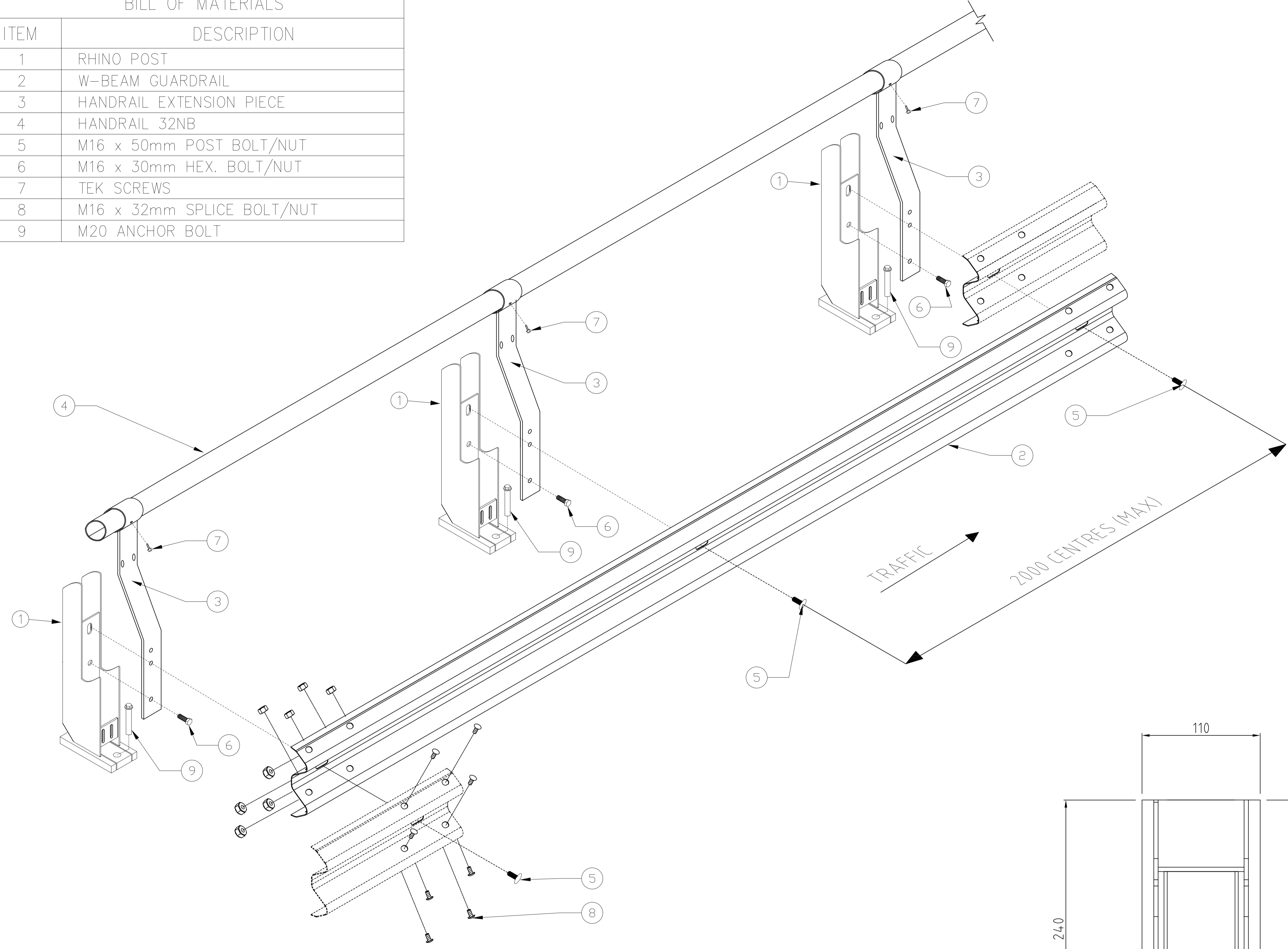
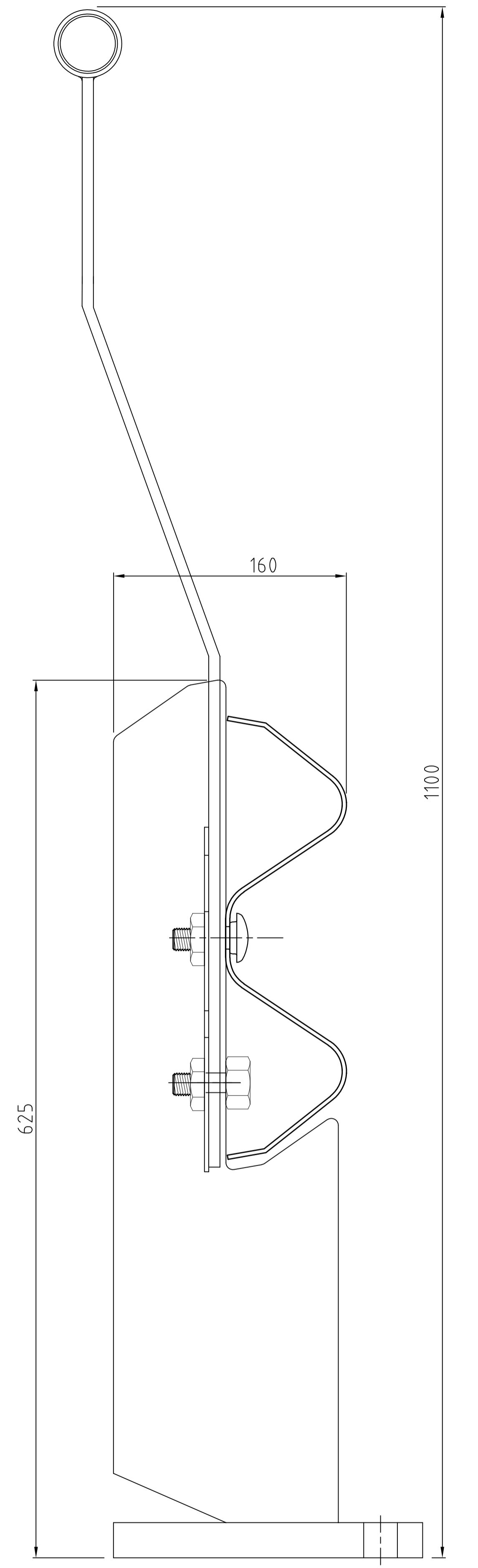

POST ELEVATION

RHINO-STOP HAS BEEN ASSESSED TO EXCEED THE 30kN IMPACT LOAD AS DESCRIBED IN AS/NZS 1170.1 FOR LIGHT TRAFFIC AREAS.

REV	DATE	DESCRIPTION	DRAWN	APPRD.
B	12.07.17	NEW HANDRAIL EXTENSION ADDED	MS	TC
A	23.10.13	INITIAL ISSUE	DB	TC

REV	DATE	DESCRIPTION	DRAWN	APPRD.



DRAWING DESCRIPTION

RHINO-STOP TYPE 3 ASSEMBLY

DRAWING REFERENCE

GR-WB-022

DRAWN BY	M. SEAL	DIMENSIONS	mm
CHECKED	H. WALLACE	SCALE	NTS
APPROVED	T. COLQUHOUN		