

BILL OF MATERIALS	
ITEM	DESCRIPTION
1	RHINO POST
2	W-BEAM GUARDRAIL
3	M16 x 50mm POST BOLT/NUT
4	M16 x 32mm SPLICE BOLT/NUT
5	M20 ANCHOR BOLT

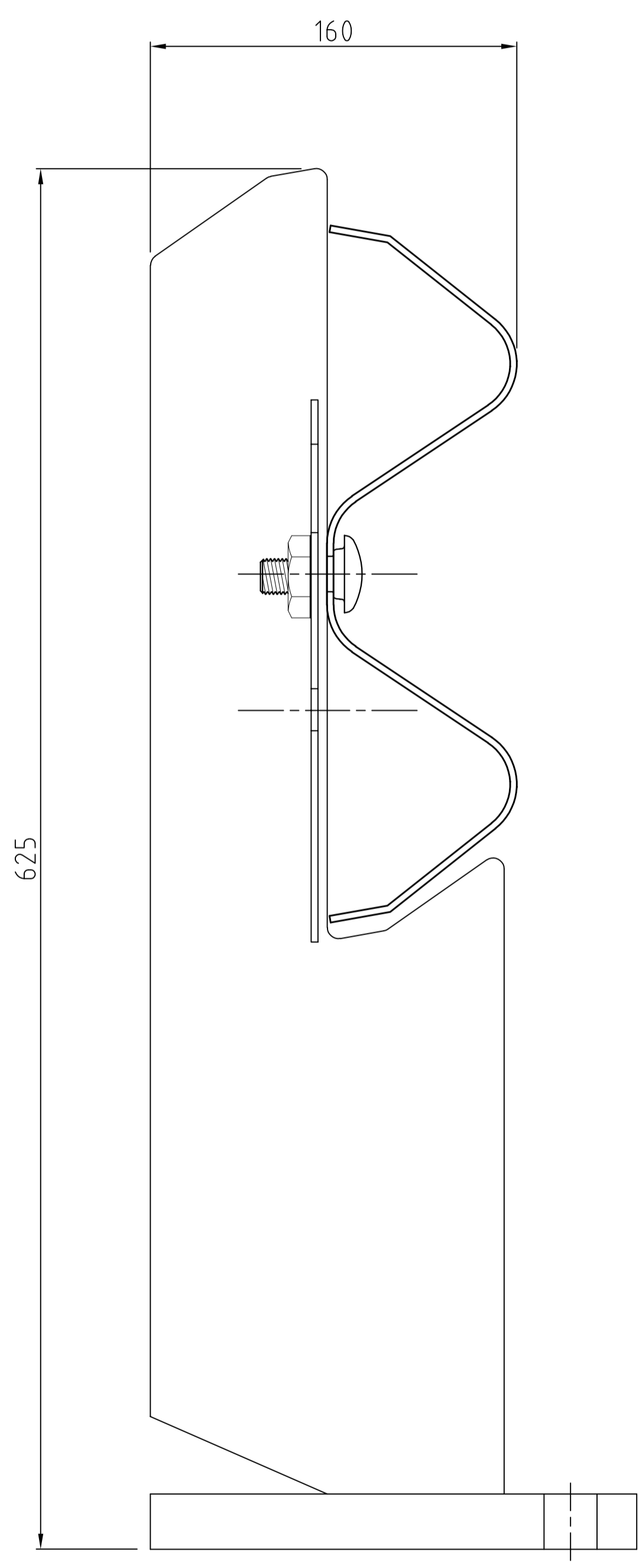
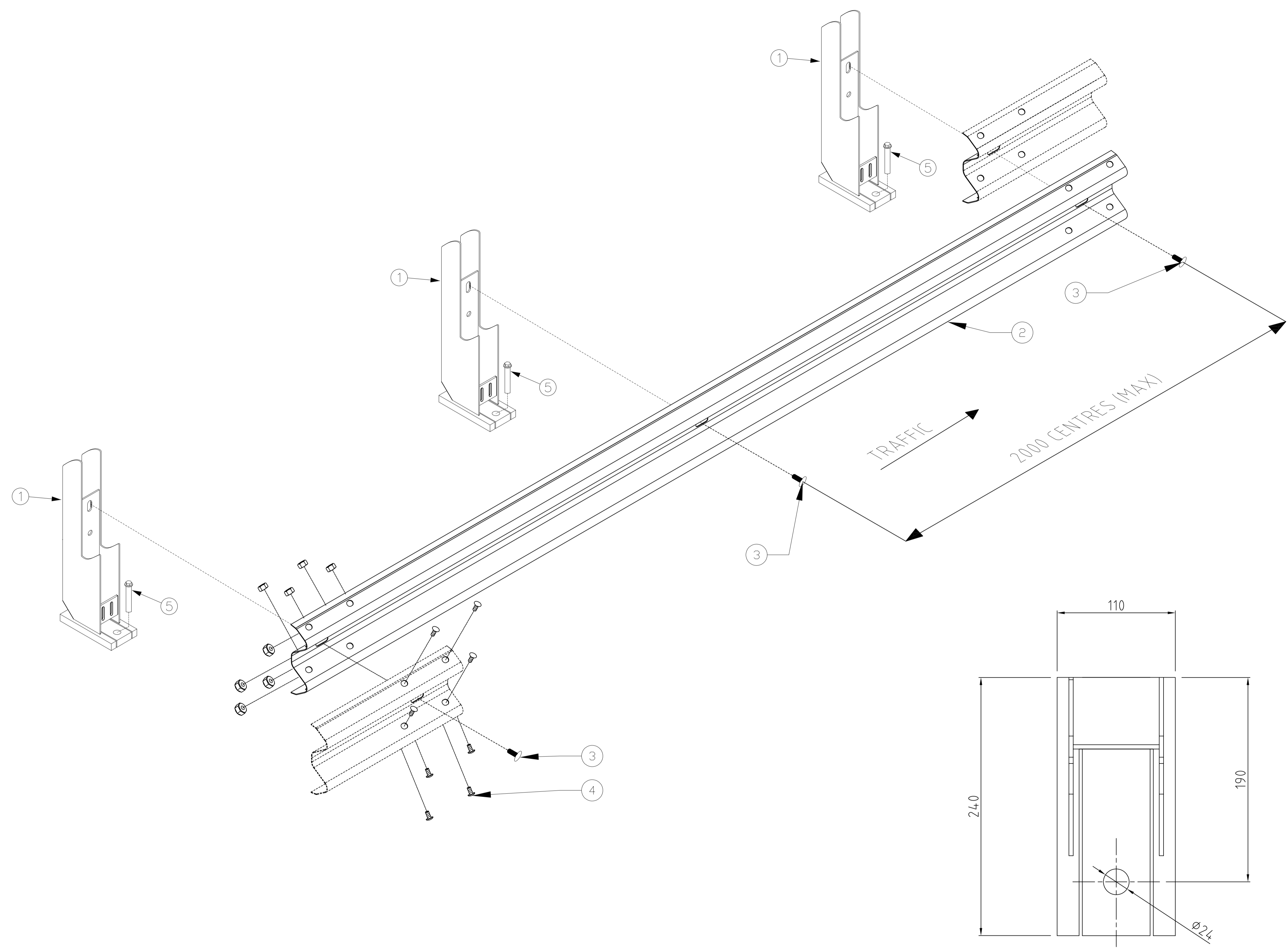

BASE PLATE DETAIL

POST ELEVATION

RHINO-STOP HAS BEEN ASSESSED TO EXCEED THE 30kN IMPACT LOAD AS DESCRIBED IN AS/NZS 1170.1 FOR LIGHT TRAFFIC AREAS.

REV	DATE	DESCRIPTION	DRAWN	APPRD.
B	13.07.17	PLATE ADDED TO POST	MS	TC
A	17.10.13	INITIAL ISSUE	DB	TC

REV	DATE	DESCRIPTION	DRAWN	APPRD.



DRAWING DESCRIPTION	RHINO-STOP TYPE 1 ASSEMBLY			
	DRAWN BY	M. SEAL	DIMENSIONS	mm
DRAWING REFERENCE	GR-WB-020			
	CHECKED	H. WALLACE	SCALE	NTS
APPROVED	T. COLQUHOUN			